

# Lesson 11.3

Name \_\_\_\_\_

## Measure and Draw Angles

COMMON CORE STANDARD CC.4.MD.6

Geometric measurement: understand concepts of angle and measure angles.

Use a protractor to find the angle measure.

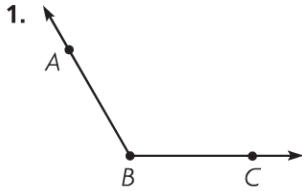

$m\angle ABC = 120^\circ$

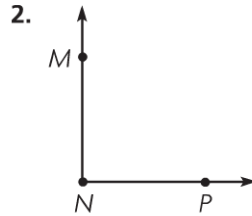

$m\angle MNP =$  \_\_\_\_\_

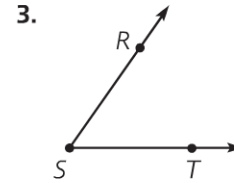

$m\angle RST =$  \_\_\_\_\_

Use a protractor to draw the angle.

4.  $40^\circ$

5.  $170^\circ$

Draw an example of each. Label the angle with its measure.

6. a right angle

7. an acute angle

© Houghton Mifflin Harcourt Publishing Company

### Problem Solving



The drawing shows the angles a stair tread makes with a support board along a wall. Use your protractor to measure the angles.

8. What is the measure of  $\angle A$ ? \_\_\_\_\_

9. What is the measure of  $\angle B$ ? \_\_\_\_\_

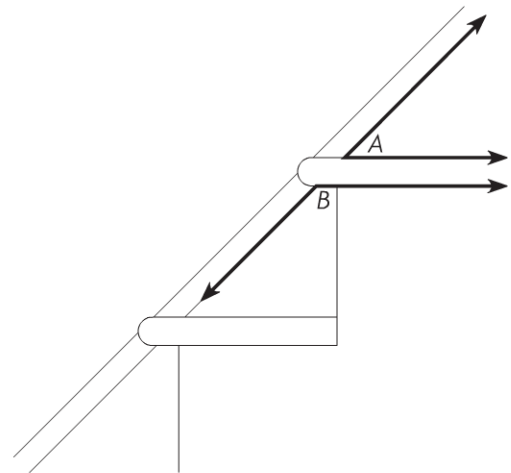

**Lesson Check** (CC.4.MD.6)

1. What is the measure of  $\angle ABC$ ?

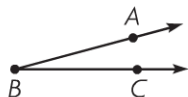

- (A)  $15^\circ$                       (C)  $155^\circ$   
 (B)  $25^\circ$                       (D)  $165^\circ$

2. What is the measure of  $\angle XYZ$ ?

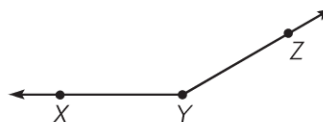

- (A)  $20^\circ$                       (C)  $150^\circ$   
 (B)  $30^\circ$                       (D)  $160^\circ$

**Spiral Review** (CC.4.NBT.6, CC.4.NF.3c, CC.4.MD.5a, CC.4.G.1)

3. Derrick earned \$1,472 during the 4 weeks he had his summer job. If he earned the same amount each week, how much did he earn each week?

(Lesson 4.10)

- (A) \$360  
 (B) \$368  
 (C) \$3,680  
 (D) \$5,888

4. Arthur baked  $1\frac{7}{12}$  dozen muffins. Nina baked  $1\frac{1}{12}$  dozen muffins. How many dozen muffins did they bake in all?

(Lesson 7.7)

- (A)  $3\frac{2}{3}$   
 (B)  $2\frac{2}{3}$   
 (C)  $2\frac{1}{2}$   
 (D)  $\frac{6}{12}$

5. Trisha drew the figure below. What figure did she draw? (Lesson 10.1)

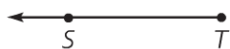

- (A) line segment  $ST$   
 (B) ray  $ST$   
 (C) ray  $TS$   
 (D) line  $TS$

6. Which describes the turn shown by the angle? (Lesson 11.1)

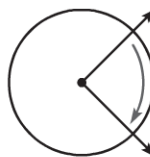

- (A) 1 full turn clockwise  
 (B)  $\frac{3}{4}$  turn clockwise  
 (C)  $\frac{1}{2}$  turn clockwise  
 (D)  $\frac{1}{4}$  turn clockwise